

## Smooth and Stepped Generator

for music synthesizers.

The previous version can be found [here](#).

This module is a variation on the Classic Serge Smooth and Stepped Generator module. It is presented here for those who want to build themselves a classic Serge. There are both the Smooth and Stepped Generator sections, as well as a small unused circuit left over from other applications on the PCB.

### From the 1982 Serge catalog:

The SMOOTH & STEPPED FUNCTION GENERATOR (SSG) is a complex multi-functional module to provide various slew and sample functions.

The Smooth section will place a positive and negative slew (glide) on a changing input voltage for lag effects, voltage controlled portamento, and non-linear, low frequency filtering. With the CYCLE jack patched to the input, the Unit will oscillate yielding a voltage controlled triangle wave LFO. A high level into the HOLD input will hold the current output level, whether the unit is oscillating or processing an external control voltage. This is identical to a track-and-hold function.

The Stepped function can be used as a sample-and-hold with voltage controlled slew rate limiting. Slew rate limiting limits the size of the step at the output. With the step size limited to a small value, if the input is a random voltage, the output is a random voltage also, but it will only vary slightly from step to step, gradually covering the entire range of the input random voltage. No large changes in the output will be allowed. With the Cycle jack patched to the input and a trigger applied to the Sample input, complex staircase waveforms are generated.

The COUPLER is an internal comparator comparing the Smooth and the Stepped outputs. This is useful for generating complex control voltages and for patching a random voltage generator.

### A little on how it works:

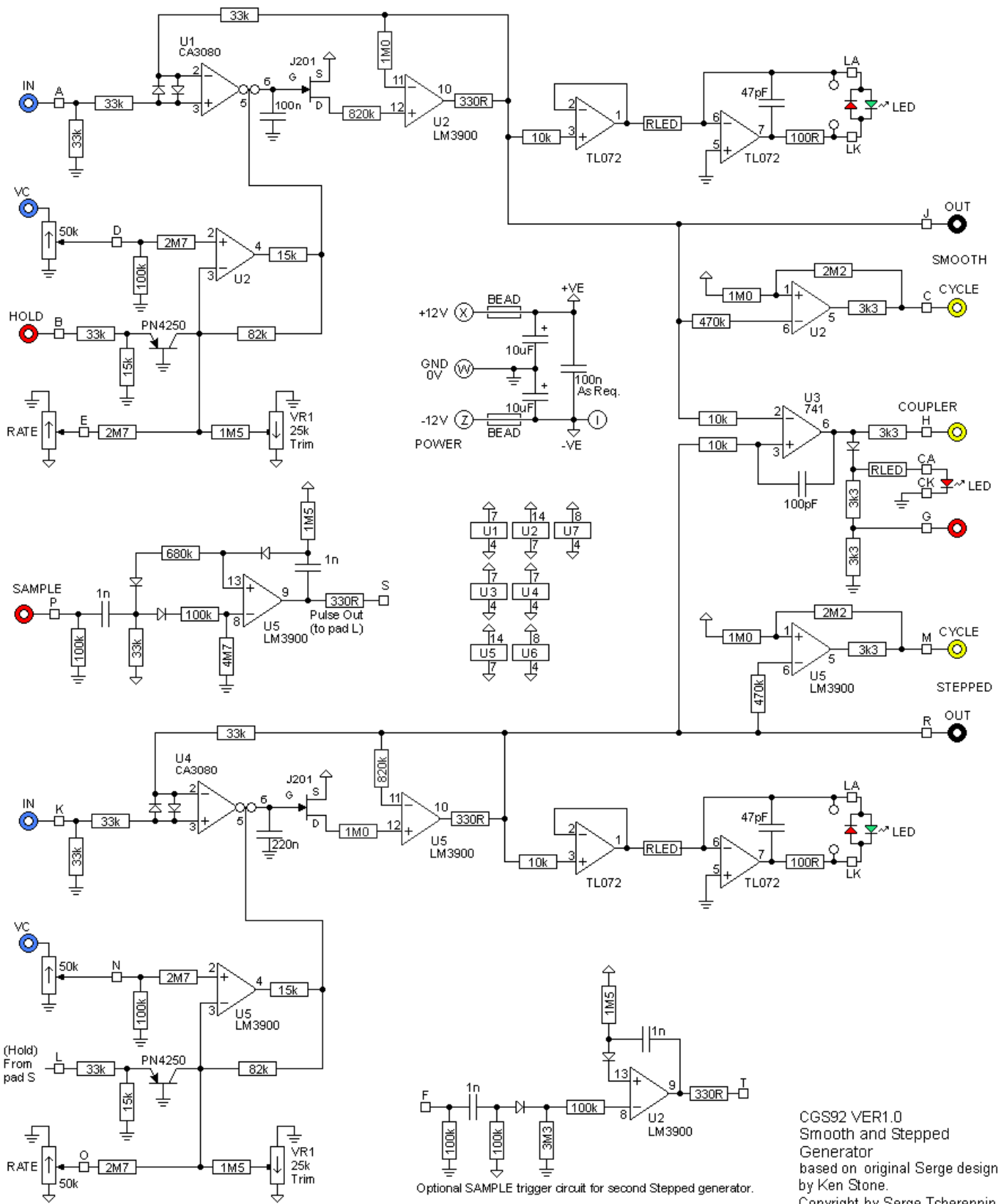

CGS92 VER1.0  
 Smooth and Stepped  
 Generator  
 based on original Serge design  
 by Ken Stone.  
 Copyright by Serge Tcherepnin

The schematic for Smooth and Stepped Generator module. Both sections are essentially identical.  
**Construction**

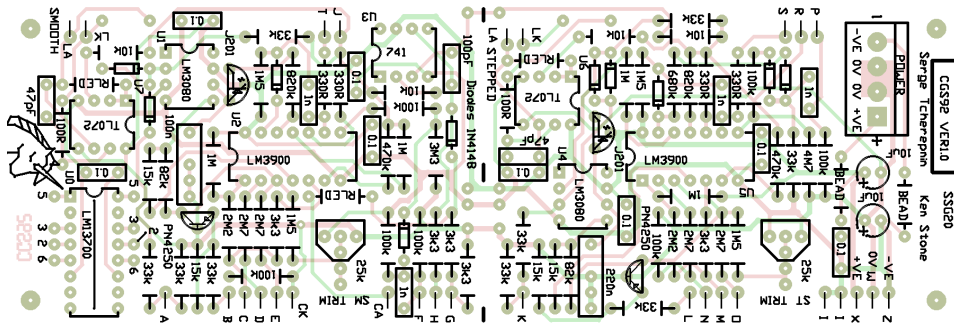

The component overlay for the VER1.0 PCB. [Click here for an enlarged, printable version. Print at 300dpi.](#)

Before you start assembly, check the board for etching faults. Look for any shorts between tracks, or open circuits due to over etching. Take this opportunity to sand the edges of the board if needed, removing any splinters or rough edges.

When you are happy with the printed circuit board, construction can proceed as normal, starting with low profile components such as resistors and diodes first, followed by successively taller components.

Take particular care with the orientation of the polarized components, such as ICs, electrolytics, diodes, and transistors.

When inserting the ICs in their sockets, if used, take care not to accidentally bend any of the pins under the chip. Also, make sure the notch on the chip is aligned with the notch marked on the PCB overlay.

Any general purpose PNP silicon transistors should work in this circuit. Take care with your connections, as some have reversed pin outs to the PN4250. **Getting the transistors backwards WILL destroy the chips.** Likewise, any general purpose FET should also work.

The unit will run on either +/-12 volts or +/-15 volts.

If you are building this with colored Banana jacks to the Serge standard, Serge recommends using a non-standard color such as yellow for the coupler (H) and cycle outputs due to their outputs swinging from to near power supply voltages. If you chose to use the G coupler output, a red jack would be appropriate.

Parts used in the circuit between pads F and T can be omitted without affecting the operation of the circuit, although their cost is so small you may as well install them in case you ever wish to experiment with that pulse converter.

Any trimpots between 20k and 100k are suitable for use.

Serge suggests that linear pots between 30k and 50k are suitable for use. My prototype uses 100k pots without trouble.

For use with regular and bipolar LEDs, RLED should be 1k. If you use high-brightness LEDs, you will need to experiment to find a suitable value.

**The first time you power it up, I would suggest you do so with 22 ohm resistors in series with the positive and negative power rails. This should save the chips if you have made a blunder.**

PAD ID	Function
A	Smooth input
B	Hold input
C	Smooth Cycle output (+/- swing close to power supply voltage)
D	Smooth VC input
E	Smooth Rate pot wiper
F	Gate to Trigger converter input (not used)
G	Coupler output (approx 0 to 5V swing when powered by +/-15 volts)
H	Coupler output (+/- swing close to power supply voltage)
I	-VE connection for pots.
J	Smooth Output
K	Stepped input
L	Connects to S pad (Hold input)
M	Stepped Cycle output (+/- swing close to power supply voltage)
N	Stepped VC input
O	Stepped Rate pot wiper
P	Stepped Sample input
R	Stepped output
S	Connects to pad L
T	Gate to Trigger converter output (not used)

W	0V power connection
X	+12V power connection
Z	-12V power connection

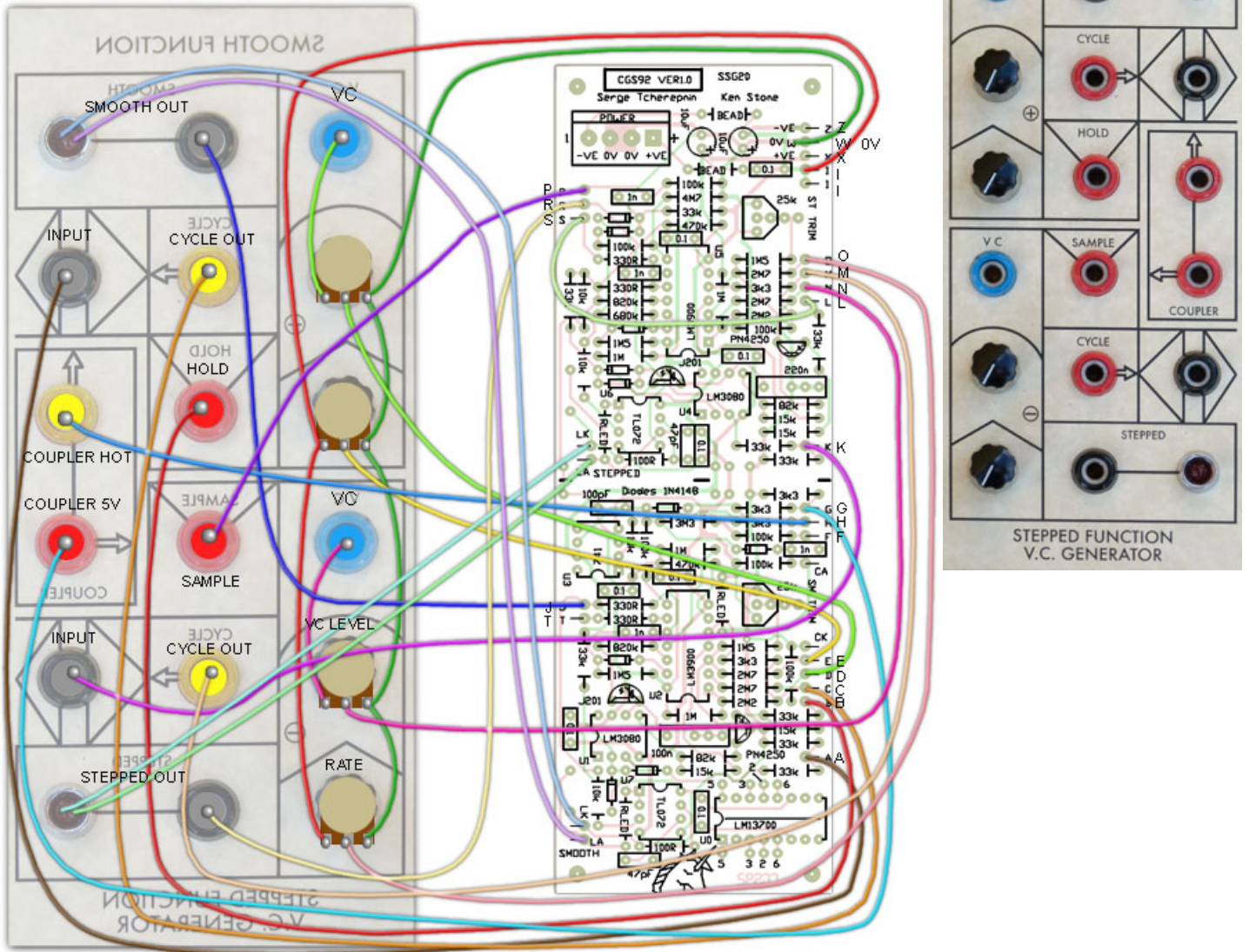

Example wiring for the Smooth and Stepped Generator.

**Set Up**

From Serge kit instructions:

For this module to work properly, a jumper must be installed between pad S and pad L. (This should have been installed during construction, although if you wish to test the two parts of the Stepped generator individually, it can be left disconnected until you have.)

Patch the CYCLE output of the Smooth Function into the IN jack. Monitor the OUTPUT while turning the RATE knob full clockwise. The pitch should be about 100 Hz, and should go to sub-audio rates (as seen from the LED'S) when the knob is turned down. Check that a control voltage into the VC IN jack will control the rate. Note that this is an attenuating input only, with no inverting processing.

A high level applied to the HOLD input (greater than about 4.5 volts) should stop the Smooth Function from cycling. With the Smooth Function patched to cycle, connect the CYCLE of the Smooth Function into the SAMPLE input of the Stepped Function. Patch the Stepped Function CYCLE to its IN jack. Using the STEPPED OUT to control the pitch of an oscillator, listen for the pitch change motion as the Stepped RATE is turned up. When fully clockwise, a triangular "staircase" waveform will be generated by the Stepped Function Generator. For best audible rate, the Smooth Function should be fairly slow. As the Stepped RATE knob is turned down, the staircase will slow down.

Note: I was unable to get a satisfactory result from the Stepped function using these procedures, instead simply adjusting the trimmer until it worked as expected.

**Notes:**

- 330R refers to 330 ohms. 100n = 0.1 uF.
- The module will work on +/-12 volts or +/-15 volts.

- **PCB info:** 6" x 2" with 3mm mounting holes 0.15" in from the edges.
- Please [e-mail me](#) if you find any errors.

## Parts list

This is a guide only. Parts needed will vary with individual constructor's needs.

If anyone is interested in buying these boards, please check the [PCBs for Sale](#) page to see if I have any in stock.

Can't find the parts? See the [parts FAQ](#) to see if I've already answered the question. Also see the [CGS Synth discussion group](#).

Part	Quantity
<b>Capacitors</b>	
47pF	2
100pF	1
1n (MKT etc)	4
100n/0.1 (Monolithic ceramic)	8
100n (MKT etc)	1
220n (MKT etc)	1
10uF 25V	2
<b>Resistors</b>	
100R	2
330R	4
RLED 1k	2
3k3	5
10k	4
15k	4
33k	9
82k	2
100k	7
470k	2
680k	1
820k	2
1M	4
1M5	4
2M2	2
2M7	4
3M3	1
4M7	1
25k (100k) trimmers	2
<b>Semi's</b>	
1N4148	10
J201 or sim (N channel JFET)	2
PN4250 or sim	2
741	1
LM3080/CA3080	2
LM3900	2
TL072	2
<b>Misc.</b>	
Jacks	as needed
Ferrite Bead (or 10R resistor)	2
0.156 4 pin connector	1
<a href="#">CGS92 VER1.0 PCB</a>	1

Article, art & design copyright 2013 by [Ken Stone](#)

[Modular Synth Home](#)

[Disclaimer](#)